

Physics Marking Period 1 Exam Review

1. You hold a green, a purple and a red rod with rubber gloves so that no charge can flow between you and the rods. Initially, the green rod has a charge of 1.0 mC of charge, the purple rod has 2.0 mC of charge and the red rod has -3.0 mC of charge. You touch some of the rods together, and then observe that the combined charge on the green and purple rods is negative .25 mC. What is the charge on the red rod?
2. What is the net force on q_2 ? Be sure to indicate direction.

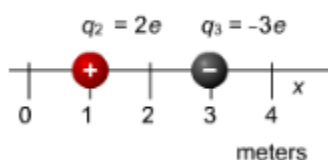

Which of the following could not be the electric charge of a particle?

- 8.00e-19 C 3.60e-18 C -2.72e-18 C -1.44e-18 C 6.72e-18 C

- 3.
4. Vanessa has been walking around all day, and electrons that rubbed off from the carpet have caused her to acquire a net negative charge. Explain why her hair might stand on end.
5. The game of checkers has two players, black and red. Each player has 12 pieces. Suppose each red piece has a charge of $+2.10 \times 10^{-15}$ coulomb and each black piece has a charge of -5.00×10^{-16} C. Find the net charge of the following systems: (a) a black piece and a red piece, (b) two black pieces and a red piece, (c) all the pieces.
6. The single electron and the single proton in a hydrogen atom in its lowest energy state are separated by a tiny distance called the Bohr radius, 5.29×10^{-11} m. Both particles carry a charge of magnitude $e = 1.60 \times 10^{-19}$ C. (a) Is the force between them attractive or repulsive? (b) What is the magnitude of the force?
7. Two steel juggling balls each carry a charge of $2.75 \mu\text{C}$. There is a repulsive force between them of 1.45 N. What is the distance between the centers of the two balls?

8. Two balls have a separation between their centers of 5.33 cm. The same electric charge is placed on both balls so that there is a repulsive force between them of 2.75 N. Assume that the charge is uniformly distributed over each ball. What is the magnitude of the charge?
9. You apply a steady potential difference of 1.50 V across an unknown component and 0.50 A of current flows through. You apply 15.0 V of potential difference and 2.5 A of current flows through. Is the component an Ohmic Resistor?
10. You are making a loop in a circuit and the changes in the electric potential as you are about to complete the loop have been +5.00 V, +8.00V and -6.00 V. There is one more component to go: What change in electric potential must you encounter there?
11. You encounter two parallel branches in a circuit. What must be true of these branches?
 - a. The same amount of current flows through them
 - b. There is the same potential difference across them
 - c. They have the same resistance
12. There are two resistors in series. You measure the same potential difference across each resistor. Which of the following is true?
 - a. The same amount of current flows through them and they have identical resistances.
 - b. Different amounts of current flow through them but they have identical resistances
 - c. The same amount of current flows through them but they have different resistances
 - d. Different amounts of current flow through them but they have different resistances
13. Three wires meet at a junction. 4.50 A of current flows through wire #1 into that junction, and 3.00 A flows out of the junction through wire #2. How much current flows into or out the junction through wire #3?

14. In the circuit shown, the current through the 4 ohm resistor is 2A. What potential difference is the battery providing?

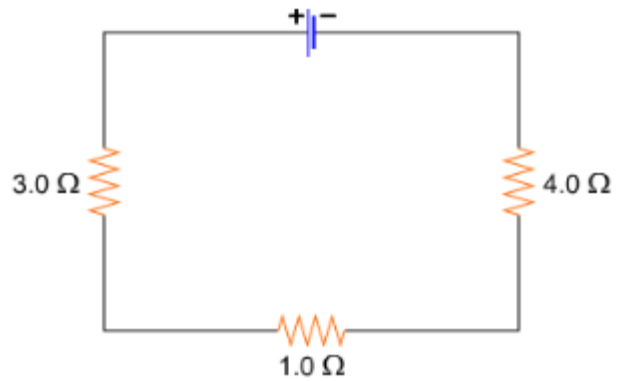

15. An electron is moving as shown by the velocity vector. What is the direction of the force the magnetic field exerts on the charge?

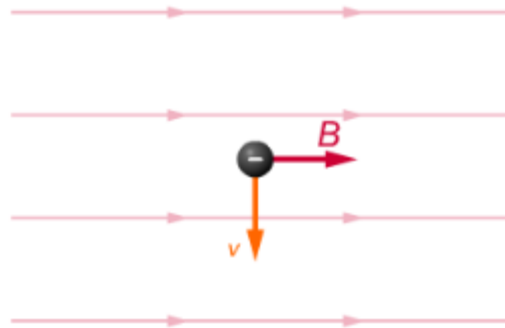

16. A large spool holding a coil of hundreds of loops of telephone cable is loaded on a truck at the factory in New York, and transported to a utility in Georgia. During the trip, a meter which is attached to the coil registers a tiny intermittent current in the coil. If there is no battery attached to the coil, what is the cause of the current?
17. A circular loop of wire is located in a constant, uniform magnetic field. How can a current be induced in the loop?
18. How is the earth magnetically different than the moon?
19. What are the four fundamental forces and give and what does each one do?
20. How many quarks are in a proton?
21. A charge of 3.40 C is build up in a Tesla Coil. This charge is released through the air into the ground in 3.4×10^{-6} s.
- What is the current of this discharge?
 - What was the voltage difference between the Tesla Coil and the ground?

22. Draw a picture of two bar magnets that repel each other.

23. Explain why a magnet falling through a copper tube falls much more slowly than it would outside of the copper tube.

24. Find the current through each resistor.

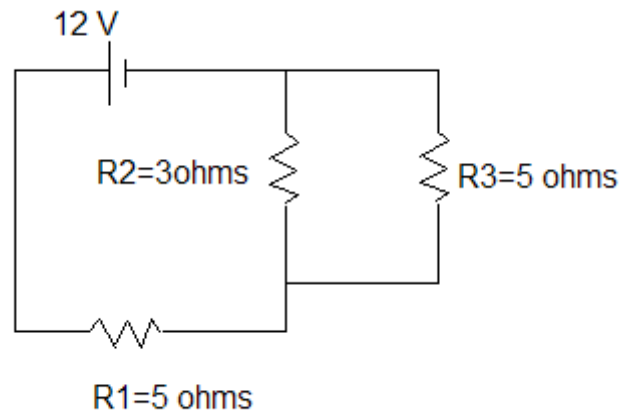

25. Find the current through each resistor.

$R1 = 2\Omega$

$R2 = 3\Omega$

$R3 = 1\Omega$

$R4 = 3\Omega$

